

# UEBERALL Multi-Media Water Filter

## UMF-75

For deep sand filtration of potable water.  
 Made of Stainless Steel 304 for 20+ years lifetime expectation under 2 years warranty.  
 Complete operational system including initial fillings and all necessary manual valves (butterfly valves) with handles.



### Schematic and Valve list

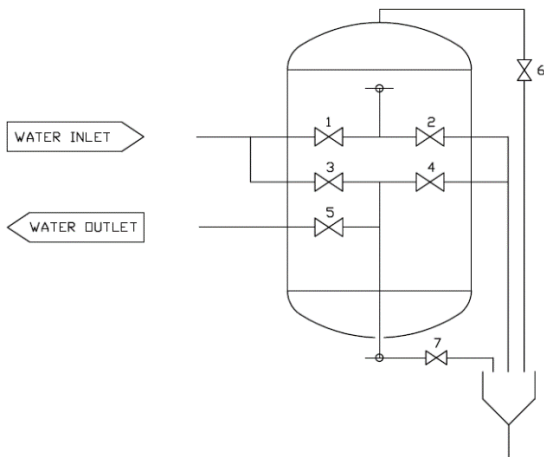

	Valve Function	Size
1	Water Inlet	DN 150
2	Backwash outlet	DN 150
3	Backwash inlet	DN 150
4	Rinse	DN 150
5	Water Outlet	DN 150
6	Vent	DN 25
7	Drain	DN 50

### Technical Data

Filter Cyl. H x D:	1200 x 2200 mm	Flow rate nominal:	75 m <sup>3</sup> /h
Filter area:	3,79 m <sup>2</sup>	Flow rate max.:	110 m <sup>3</sup> /h
Support layer:	2075 kg	Flow rate back wash:	136 m <sup>3</sup> /h
Filter Sand:	2275 kg		
Hydroanthrasit /		Operational Pressure:	6 bar
Activated Carbon:	1625 kg	Test Pressure:	9 bar

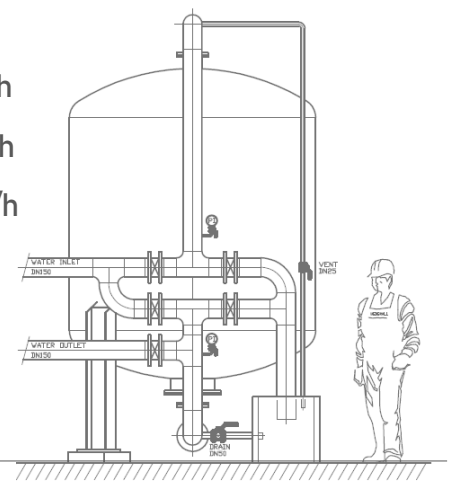

**Options:** Automatic backflush with control panel and all necessary butterfly Valves with electro-pneumatic drive (requires pressurized air 8-10bar)